JOURNAL OF THE AMERICAN CHEMICAL SOCIETY

Spontaneous Cleavage of 4'-DNA Radicals under Aerobic Conditions: Apparent Discrepancy between Trapping Rates and Cleavage Products

Adrian Dussy, Eric Meggers, and Bernd Giese*

Contribution from the Department of Chemistry, University of Basel, St. Johanns-Ring 19,
CH-4056 Basel, Switzerland

Received January 5, 1998

Abstract: The O₂-induced strand scission of 4'-DNA radicals is initiated by a reversible O₂ addition reaction. The rate coefficient of the O₂ release from the single-stranded 4'-DNA peroxy radical is 1.0 s⁻¹ at 20 °C. Because of this reversibility, an O₂-dependent strand cleavage occurs only in the presence of H-donors that trap the 4'-DNA peroxy radicals, yielding DNA hydroperoxides. At very low H-donor concentrations the strand scission is the result of an O₂-independent, spontaneous reaction even under aerobic conditions. Nevertheless, oxidative products can be formed from the fragments of this spontaneous DNA cleavage.

Introduction

4'-DNA radicals **2** are important intermediates in radical-induced DNA cleavage reactions.¹ In the presence of O₂ radical **2** is trapped and generates hydroperoxide **4**, which yields via a Criegee rearrangement and subsequent elimination and substitution steps the 5'-phosphate **5** and 3'-phosphoglycolate **6** as oligomeric cleavage products (Scheme 1). In the absence of O₂ strand scission occurs by a spontaneous heterolytic β-C,O bond cleavage.^{1,2} This leads to 5'-phosphate **5** and DNA radical cation **7**, which is trapped by H₂O and yields 3'-phosphate **8** in a second β-C,O bond scission reaction. Whereas 5'-phosphate **5** is formed under both aerobic and anaerobic reaction condi-

tions, the typical aerobic cleavage product is 3'-phosphoglycolate **6**, whereas the 3'-phosphate **8** is characteristic for anaerobic conditions.

Recently, we have determined the rate coefficient k_E for the spontaneous cleavage reaction³ of single-stranded 4'-DNA radicals (**2** → **5** + **7**) to about 10³ s⁻¹. Because the rate coefficient k_{O_2} of O₂ addition to alkyl radicals⁴ is 2 × 10⁹ M⁻¹ s⁻¹, and the O₂ concentration of air in H₂O is 2.5 × 10⁻⁴ M, the O₂-trapping reaction of the 4'-DNA radicals (**2** + O₂ → **3**) under atmospheric aerobic conditions is about 500 times faster ($k_{O_2}[O_2]/k_E$) than the spontaneous strand scission (**2** → **5** + **7**). Therefore, formation of 3'-phosphate **8**, the product of the spontaneous cleavage reaction, should not contribute to the products in the presence of O₂. In contrast to this expectation, we have recently observed the appearance of 3'-phosphate **8** also under aerobic conditions.^{2c,5} Because of this striking disagreement between products and rate coefficients, we deter-

(1) For reviews see: (a) Stubbe, J.; Kozarich, J. W. *Chem. Rev.* **1987**, *87*, 1107. (b) Pratviel, G.; Bernadou, J.; Meunier, B. *Angew. Chem., Int. Ed. Engl.* **1995**, *34*, 746. (c) Breen, A. P.; Murphy, J. A. *Free Radical Biol. Med.* **1995**, *18*, 1033.

(2) (a) von Sonntag, C. *The Chemical Basis of Radiation Biology*; Taylor and Francis: London, 1987. (b) Schulte-Frohlinde, D. *Chem. Zeit* **1990**, *1310*. (c) Giese, B.; Beyrich-Graf, X.; Erdmann, P.; Petretta, M.; Schwitter, U. *Chem. Biol.* **1995**, *2*, 367.

(3) Giese, B.; Dussy, A.; Meggers, E.; Petretta, M.; Schwitter, U. *J. Am. Chem. Soc.* **1997**, *119*, 11130.

(4) Willson, R. L. *Trans Faraday Soc.* **1971**, *67*, 3008.

Scheme 1

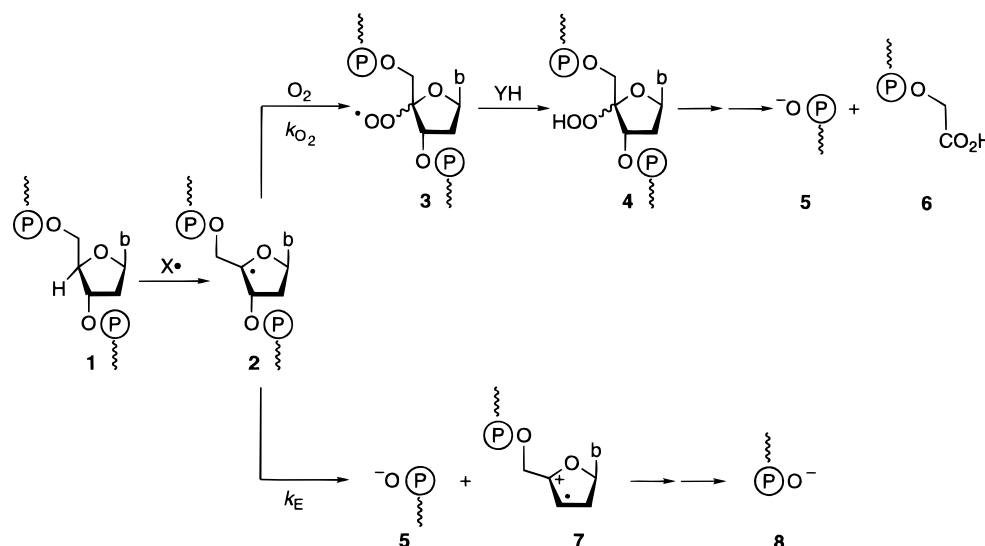

mined the velocity of the product formation in O₂-dependent single-strand scission reactions of 4'-DNA radical 2.

Experimental Section

General Methods and Materials. All reagents are commercially available and used without further purification. MS: Vestec, Benchtop II for MALDI-ToF (matrix, 2,4-dihydroxyacetophenone; laser wavelength, 337 nm; acceleration voltage, 25 kV, negative ions). The oligonucleotides were synthesized using an Expedite synthesizer from Perseptive Biosystems GmbH applying standard phosphoramidite chemistry. Chemicals for DNA synthesis were purchased from MWG. The 4'-pivaloyl thymidine was synthesized according to literature.⁶ Optical densities (OD) were measured on a Perkin-Elmer Lambda II UV/vis spectrometer. HPLC: Hewlett-Packard 1050 chromatograph with UV detector (260 nm) and Waters alliance system with diode array detector; HPLC on Merck LiChrospher 100 RP-18 end-capped, 250–4 mm, 5 μm. Photolysis were performed with an Osram Hg high-pressure lamp (500 W, 320 nm cutoff filter) in a 5 × 10 mm poly(methyl methacrylate) cuvette. Oligonucleotides 1, 5'-phosphate 5, glycolate 6, and 3'-phosphate 8 were identified by independent synthesis and comparison of retention times in the HPLC and by MALDI-ToF MS. All other cleavage products were identified by MALDI-ToF MS. The solutions were prepared with Nanopure water from a Barnstead NANOpure water system. O₂ concentrations were determined with a WTW Oxi 537 O₂-sensitive electrode. Calculations were performed on an Apple Power Macintosh 7300/166 with proFit 5.0.1 from Quantum Soft.

Extinction coefficients were calculated by increments. The following extinction coefficients (λ = 260 nm) were utilized to quantify the oligonucleotides, where T* means 4'-pivaloyl-substituted thymidine: d(CGCGT*ACTGCT), ε = 103.4 mM⁻¹ cm⁻¹; d(pTACTGCT), ε = 61.3 mM⁻¹ cm⁻¹; d(TTCCCT*TTTTTTTT), ε = 114.8 mM⁻¹ cm⁻¹; d(GCGAT*ATCGGCT), ε = 113.3 mM⁻¹ cm⁻¹; d(pTTTTTTTT), ε = 73.5 mM⁻¹ cm⁻¹; d(pATCGGCT), ε = 63.9 mM⁻¹ cm⁻¹.

Determination of the H-Abstraction Rate from Glutathione (GSH) by a 4'-DNA Radical under Anaerobic Conditions. To determine the H-transfer rates of GSH to 4'-DNA radicals, we first determined the anaerobic cleavage rate of these 4'-DNA radicals by trapping experiments with a H-donor (glutathione diethyl ester) whose absolute reaction rate coefficient is known.^{3,7} This DNA strand cleavage

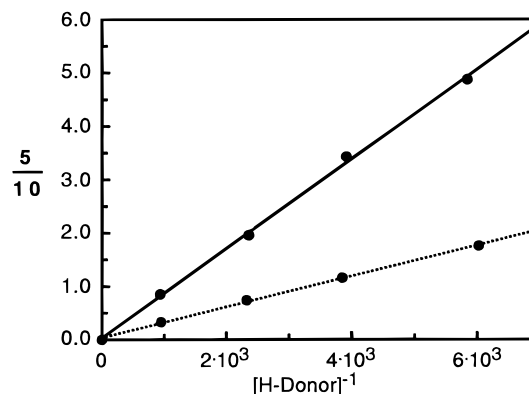

Figure 1. Formation of cleavage product 5 and H abstraction products 10 with different H-donor concentrations in the absence of O₂. The experiments were carried out with d(TTCCCT*TTTTTTTT) as radical precursor, where T* is a 4'-pivaloyl-substituted thymidine, glutathione diethyl ester (solid line), and glutathione (broken line). Compound 5 stands for d(pTTTTTTTT) and 10 for d(TTCCCT°TTTTTTTT), where T° is a mixture of the D-deoxyribonucleotide and its 4'-epimer.

rate was then used to determine the rate of the H-abstraction from GSH in pseudo-first-order kinetic experiments.

A buffered aqueous solution (200 μL, 20 mM phosphate, pH 7.0, 0.1 M NaCl) of 0.4–0.5 nmol of single-stranded oligonucleotides d(TTCCCT*TTTTTTTT) or d(GCGAT*ATCGGCT) and 30–200 nmol of glutathione diethyl ester or glutathione was deoxygenated by treatment with argon. The solution was irradiated for 3 min (Osram 500 W, 320 nm cutoff filter) in a poly(methyl methacrylate) cuvette at 20 °C and injected without workup on a reversed phase HPLC-column (flow rate 1 mL min⁻¹, 50 °C). Eluent A was 0.1 M triethylammonium acetate, and eluent B was acetonitrile. Elution was carried out by using a 7–15% B linear gradient over 40 min for d(TTCCCT*TTTTTTTT) and a 2–12% B linear gradient for d(GCGAT*ATCGGCT). Under these conditions the single-stranded educt oligomers d(TTCCCT*TTTTTTTT) and d(GCGAT*ATCGGCT), the cleaved oligomers d(pTTTTTTTT) and d(pATCGGCT), and the H-trapped oligomers d(TTCCCT°TTTTTTTT) and d(GCGAT°ATCGGCT), where T° means a mixture of the D-deoxyribonucleotide and its 4'-epimer, could be separated and quantified. The ratios d(pATCGGCT)/d(GCGAT°ATCGGCT) and d(pTTTTTTTT)/d(TTCCCT°TTTTTTTT) (Figure 1) were plotted against the reciprocal H-donor concentrations. Using a H-donor rate coefficient of 1.0 × 10⁷ M⁻¹ s⁻¹ for glutathione diethyl ester,⁷ a cleavage rate for the 4'-DNA radical of 0.7 × 10³ s⁻¹ for d(GCGAT*ATCGGCT) and 1.3 × 10³ s⁻¹ for d(TTCCCT*TTTTTTTT) was measured. With these cleavage rates the rate

(5) For the mechanism of the formation of 3'-phosphates with bleomycin, see: Sugiyama, H.; Xu, C.; Murugesan, N.; Hecht, S. M. *Biochemistry* **1988**, *27*, 7, 58.

(6) Marx, A.; Erdmann, P.; Senn, M.; Körner, S.; Jungo, T.; Petretta, M.; Imwinkelried, P.; Dussy, A.; Kulicke, K. J.; Macko, L.; Zehnder, M.; Giese, B. *Helv. Chim. Acta* **1996**, *79*, 1980.

(7) Tronche, C.; Martinez, F. N.; Horner, J. H.; Newcomb, M.; Senn, M.; Giese, B. *Tetrahedron Lett.* **1996**, *37*, 5845.

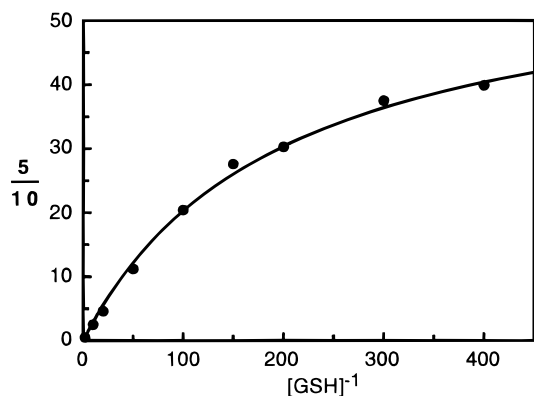

Figure 2. Formation of cleavage product **5** and H abstraction products **10** with different H-donor concentrations in the presence of O₂ (0.25 mM). The experiments were carried out with d(CGCGT*TACTGCT) as radical precursor, where T* is a 4'-pivaloyl-substituted thymidine, and glutathione. Compound **5** stands for d(pTACTGCT) and **10** for d(CGCGT°TACTGCT), where T° is a mixture of the D-deoxyribo-nucleotide and its 4'-epimer.

coefficients for GSH of $k_{CH} = 2.3 \times 10^6 \text{ M}^{-1} \text{ s}^{-1}$ and $k_{CH} = 1.5 \times 10^6 \text{ M}^{-1} \text{ s}^{-1}$, respectively, were determined.⁸

Cleavage of 4'-DNA Radicals in the Presence of O₂ and Glutathione (GSH). Samples of 2 nmol of d(CGCGT*TACTGCT) were dissolved in 200 μL (20 mM KH₂PO₄ buffer, 100 mM NaCl, and 2.5–500 mM GSH). The samples were irradiated (Osram 500W, 320 nm) at 20 °C under atmospheric O₂ (0.25 mM) for 10 min. The solutions were directly analyzed by reversed phased HPLC (flow rate 1 mL min⁻¹, 25 °C). Eluent A was 0.1 M triethylammonium acetate, and eluent B was acetonitrile. Elution was carried out by using a 5–13% B linear gradient over 50 min. Under these conditions the single-stranded oligomers d(CGCGT*TACTGCT), d(CGCGT°TACTGCT), where T° is a mixture of the D-deoxyribonucleotide and its 4'-epimer, d(pTACTGCT), d(CGCGp), and d(CGCGp-glycolate) could be separated and quantified. In Figure 2 the ratios d(pTACTGCT)/d(CGCGT°TACTGCT) were plotted against the reciprocal GSH concentration and the data fitted according to eq 2.

Results and Discussion

The single-stranded 4'-DNA radical **2** was generated by photolysis of ketone **9** (Scheme 2).⁹ To measure the formation rate of O₂-dependent products **5** and **6**, pseudo-first-order competition experiments with 2.5–500 mM glutathione (GSH) that yield H-trapping products **10** (mixture of epimers) were carried out.

We first checked whether under the kinetic conditions 5'-phosphate **5** was generated also by an O₂-independent reaction. A spontaneous strand scission of 4'-DNA radical **2** would lead to 5'-phosphate **5** and radical cation **7**. Trapping of **7** by H₂O generates radical **11** that reacts with H-donors such as GSH and forms product **12** (**11** + GSH → **12**).^{2c} Under the reaction conditions of the competition kinetic experiment compound **12** could be detected neither by HPLC nor by MALDI-ToF MS. In addition, 3'-phosphate **8**, the spontaneous cleavage product of radical **11**, was formed in only 2% yield. Because of these

(8) Because of the repulsion between the negative charges, GSH reacts about 5 times slower than the diethyl ester of GSH. See also: Zheng, S.; Newton, G. L.; Gonick, G.; Fahey, R. C.; Ward, J. F. *Radiat. Res.* **1988**, *114*, 11.

(9) Because the photolysis of **9** leads not only to 4'-DNA radical **2** but also to pivaloyl and/or *tert*-butyl radicals that might generate DNA radicals by H abstraction, we carried out independent photolysis experiments of di-*tert*-butyl ketone with unmodified oligonucleotides in the presence of O₂ and GSH. Under these conditions H abstraction from oligonucleotides with subsequent formation of strand cleavage or isomerization products could not be observed by HPLC, although the ketone was consumed within 6 min of irradiation (320 nm cutoff filter).

Scheme 2

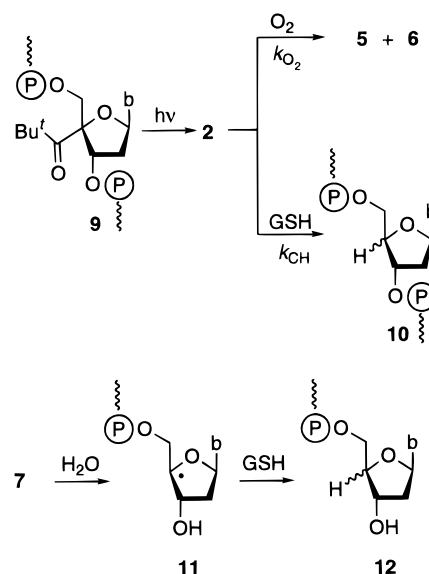

Table 1. Yields and Ratios of the H Abstraction Products **10** and Cleavage Product **5** with Different Concentrations of Glutathione (GSH) under Atmospheric O₂ at 20 °C^a

entry	[GSH] (mM)	yield of 10 ^b (%)	yield of 5 ^b (%)	5/10
1	2.5	1	54	39.9
2	3.3	1	53	37.5
3	5.0	2	51	30.3
4	6.7	2	53	27.6
5	10	3	60	20.4
6	20	6	67	11.2
7	50	15	68	4.6
8	100	23	58	2.5
9	500	51	24	0.5

^a The experiments were carried out with d(CGCGT*TACTGCT) as radical precursor, where T* is a 4'-pivaloyl-substituted thymidine.
^b Yields are based on conversion.

results, it could be assumed that the spontaneous cleavage reaction is not significant in the presence of 2.5–500 mM GSH, and the 5'-phosphate **5** could be used as a measure of the amount of O₂-induced strand scission products. The kinetic experiments were carried out under atmospheric pressure (0.25 mM in O₂) with nine different GSH concentrations. The yields of products **5** + **10**, based on the conversion, were 53–91% (Table 1).

For two competing irreversible reaction steps (O₂ versus GSH trapping of **2**) under pseudo-first-order conditions and constant O₂ concentration, a linear correlation is expected between the product ratio **5/10** and the reciprocal GSH concentration. Figure 2 demonstrates that a linear correlation exists only at very high GSH concentration. From the nearly linear part of the curve in Figure 2 (four points, 20–500 mM in GSH; Table 1, entries 6–9) a k_{CH} value for the H abstraction step (**2** + GSH → **10**) of $2.2 \times 10^6 \text{ M}^{-1} \text{ s}^{-1}$ was calculated according to

$$\frac{5}{10} = \frac{k_{O_2}[O_2]}{k_{CH}[GSH]} \quad (1)$$

With diminishing GSH concentration a curvature results and the product ratio **5/10** increases slower than expected from the ratio of the rate coefficients k_{O_2}/k_{CH} . Thus, at lower GSH concentrations the overall rate for the formation of O₂-dependent DNA cleavage products decreases. This might be caused by a reversible O₂ addition to 4'-DNA radical **2** (Scheme 3). Assuming steady-state conditions for radicals **2** and **3**, a kinetic

Scheme 3

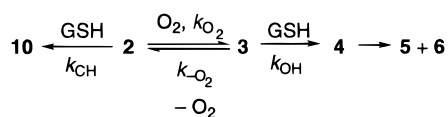

expression for a competing reaction sequence, in which one reaction ($2 + \text{O}_2 \rightleftharpoons 3$) is reversible, was deduced as

$$\frac{5}{10} = \frac{k_{\text{OH}}k_{\text{O}_2}[\text{O}_2]}{k_{\text{CH}}(k_{-\text{O}_2} + k_{\text{OH}}[\text{GSH}])} \quad (2)$$

To analyze the curvature of Figure 2 with eq 2, the literature rate coefficients $k_{\text{O}_2} = 2 \times 10^9 \text{ M}^{-1} \text{ s}^{-1}$ and $k_{\text{OH}} = 2 \times 10^2 \text{ M}^{-1} \text{ s}^{-1}$ were used.^{4,10} With these data the curvature of Figure 2 was fitted which generated the rate coefficients $k_{-\text{O}_2} = 1.0 \text{ s}^{-1}$ for the decomposition of the peroxy radical **3** and $k_{\text{CH}} = 1.6 \times 10^6 \text{ M}^{-1} \text{ s}^{-1}$ for the H abstraction of the 4'-DNA radical **2** from GSH. The H abstraction rate is in agreement with independent GSH-trapping measurements of 4'-DNA radicals ($k_{\text{CH}} = (1.9 \pm 0.4) \times 10^6 \text{ M}^{-1} \text{ s}^{-1}$; see the Experimental Section).

This agreement between the H abstraction rate coefficient demonstrates that the fitting procedure gives reliable results, and the O_2 cleavage step ($3 \rightarrow \text{O}_2 + 2$) of $k_{-\text{O}_2} = 1.0 \text{ s}^{-1}$ should also be in the right order of magnitude. Actually, the cleavage rate of the tertiary cumylperoxy radical is very similar ($k_{-\text{O}_2} = 2 \text{ s}^{-1}$),¹¹ and a reversible reaction of other bioradicals with O_2 was found by N. A. Porter et al. in the autoxidation of lipids.¹² The reaction profiles of Figure 3 were calculated with these rate coefficients. To determine the free enthalpy profiles, pseudo-first-order rate coefficients were used which contain the concentrations of O_2 and GSH. The free activation enthalpies were calculated as

$$k = (k_{\text{B}}T/h)e^{-\Delta G^\ddagger/RT} \quad (3)$$

$$\Delta G^\ddagger = -RT \ln k - RT \ln(h/k_{\text{B}}T) \quad (4)$$

At high GSH concentrations (Figure 3; $[\text{GSH}] = 1 \text{ M}$, broken line) the H addition step ($2 + \text{GSH} \rightarrow 10$) and the O_2 addition step ($2 + \text{O}_2 \rightarrow 3$) at 4'-DNA radical **2** are the two rate-determining reactions. The formation of the 4'-hydroperoxide **4** from peroxy radical **3** is so fast that the back-reaction ($3 \rightarrow 2 + \text{O}_2$) is not significant. Under constant O_2 concentrations (0.25 mM) the product ratio $5/10$ depends directly on the ratio of the rate coefficients $k_{\text{O}_2}/k_{\text{CH}}$ and the reciprocal GSH concentration. On the other hand, at low GSH concentrations (Figure 3; $[\text{GSH}] = 10^{-4} \text{ M}$, solid line), the H abstraction of the 4'-DNA peroxy radical **3** is so slow that it becomes one of the rate-determining steps of the competition system. A Curtin-Hammett situation¹³ exists where the interconversion of the radical intermediates **2** and **3** is faster than their trapping reactions.

In summary, at high H-donor concentrations, the first step, the O_2 addition to the 4'-DNA radical ($2 + \text{O}_2 \rightarrow 3$), is the rate-determining step of the hydroperoxide formation, but at low H-donor concentration, the second step, the H abstraction

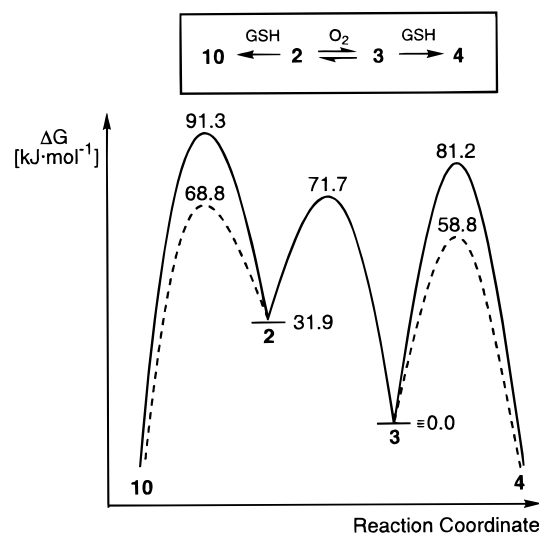

Figure 3. Reaction profile diagram for the trapping of 4'-DNA radical **2** with O_2 and glutathione (GSH). The reaction profile was calculated with the following rate coefficients: $k_{\text{O}_2} = 2 \times 10^9 \text{ M}^{-1} \text{ s}^{-1}$, $k_{-\text{O}_2} = 1.0 \text{ s}^{-1}$, $k_{\text{OH}} = 2 \times 10^2 \text{ M}^{-1} \text{ s}^{-1}$, and $k_{\text{CH}} = 1.6 \times 10^6 \text{ M}^{-1} \text{ s}^{-1}$ at 0.25 mM O_2 concentration with 10^{-4} M GSH (solid line) and 1 M GSH (broken line). All free enthalpies were referred to the free enthalpy of peroxy radical **3**.

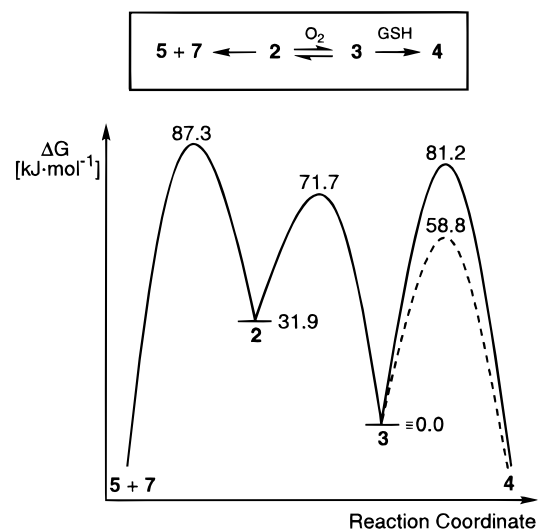

Figure 4. Reaction profile diagram for the competition between the trapping of 4'-DNA radical **2** with O_2 and spontaneous strand cleavage. The reaction profile was calculated with the following rate coefficients: $k_{\text{O}_2} = 2 \times 10^9 \text{ M}^{-1} \text{ s}^{-1}$, $k_{-\text{O}_2} = 1.0 \text{ s}^{-1}$, $k_{\text{OH}} = 2 \times 10^2 \text{ M}^{-1} \text{ s}^{-1}$, and $k_{\text{E}} = 0.8 \times 10^3 \text{ M}^{-1} \text{ s}^{-1}$ at 0.25 mM O_2 concentration with 10^{-4} M GSH (solid line) and 1 M GSH (broken line). All free enthalpies were referred to the free enthalpy of peroxy radical **3**.

by the 4'-DNA peroxy radical ($3 + \text{GSH} \rightarrow 4$), becomes the rate-limiting step. This change in the rate-determining steps explains the curvature of Figure 2.

The reaction profile for the competition between the spontaneous cleavage and the O_2 -induced cleavage of the 4'-DNA radical **2** is shown in Figure 4. Under aerobic conditions ($[\text{O}_2] = 0.25 \text{ mM}$) the O_2 -trapping step ($2 + \text{O}_2 \rightarrow 3$) is considerably faster than the spontaneous cleavage reaction ($2 \rightarrow 5 + 7$). As long as the GSH concentration is high (Figure 4; $[\text{GSH}] = 1 \text{ M}$, broken line) the peroxy radical **3** is quantitatively trapped to the hydroperoxide **4**. Therefore, cleavage products are formed only by the O_2 -induced pathway. However, at low GSH concentrations the rate-determining step for the generation of the 4'-hydroperoxide **4** is not the formation of the 4'-DNA

(10) Hildenbrand, K.; Schulte-Frohlinde, D. *Int. J. Radiat. Biol.* **1997**, *71*, 377.

(11) Howard, J. A.; Bennett, J. E.; Brunton, G. *Can. J. Chem.* **1981**, *59*, 2253.

(12) Porter, N. A.; Mills, K. A.; Carter, R. L. *J. Am. Chem. Soc.* **1994**, *116*, 6690.

(13) Seemann, J. I. *Chem. Rev.* **1983**, *83*, 83.

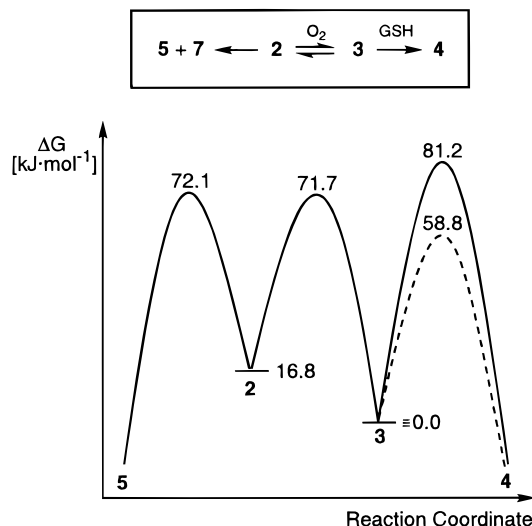

Figure 5. Reaction profile diagram for the competition between the trapping of 4'-DNA radical **2** with O_2 and spontaneous strand cleavage. The reaction profile was calculated with the following rate coefficients: $k_{O_2} = 2 \times 10^9 \text{ M}^{-1} \text{ s}^{-1}$, $k_{-O_2} = 1.0 \text{ s}^{-1}$, $k_{OH} = 2 \times 10^2 \text{ M}^{-1} \text{ s}^{-1}$, and $k_E = 0.8 \times 10^3 \text{ M}^{-1} \text{ s}^{-1}$ at $0.5 \times 10^{-6} \text{ M}$ oxygen concentration with 10^{-4} M GSH (solid line) and 1 M GSH (broken line). All free enthalpies were referred to the free enthalpy of peroxy radical **3**.

peroxy radical ($2 + O_2 \rightarrow 3$) but its reaction with the H-donor ($3 + \text{GSH} \rightarrow 4$). At 10^{-4} M GSH concentration (Figure 4, solid line) the spontaneous cleavage ($2 \rightarrow 5 + 7$) can already compete with the oxidative cleavage, and at 10^{-5} M GSH concentration (not shown in Figure 4) the transition state energies of the rate-determining steps of the spontaneous cleavage and the H abstraction by the peroxy radical are nearly the same. The effect of a further decrease of the H-donor concentration is that the O_2 -induced cleavage is slower than the spontaneous cleavage reaction. Under these very low H-donor concentrations, the oxidation product **6** is formed in part by a Grob fragmentation^{2c} of the hydroperoxide of 4'-DNA radical **11**.

Obviously, the importance of the oxidative cleavage also depends on the O_2 concentration. It is known that the intracellular oxygen concentration varies considerably between different cells and cell compartments.¹⁴ In the cell nucleus the O_2 concentration is very low because of the relatively high concentration of the polysalt DNA. For example, the nucleus of the rat liver cell contains only 55% water, and the O_2

(14) (a) Zander R. In *Oxygen Transport to Tissue II*, Proceedings of the Second International Symposium, Mainz, March 12–14, 1975; Grote, J., Ed.; Plenum Press: New York, 1975; p 463. (b) Zander, R. *Z. Naturforsch.* **1976**, *31c*, 339.

Scheme 4

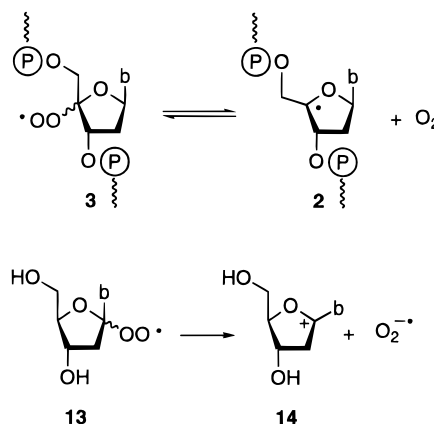

concentration is at least 10^2 – 10^3 times lower than in the plasma.¹⁴ Figure 5, where the O_2 concentration is $0.5 \times 10^{-6} \text{ M}$, mimics this situation. The transition state energies of the spontaneous cleavage ($2 \rightarrow 5 + 7$) and of the O_2 addition to the 4'-DNA radical ($2 + O_2 \rightarrow 3$) are about the same. Thus, already at relatively high GSH concentrations O_2 -independent strand scission becomes dominant. This agrees with radiolysis experiments, where radical-induced DNA strand cleavage reactions follow mainly anaerobic pathways at O_2 concentrations less than 10^{-6} M .¹⁵

It is interesting to compare the 4'-DNA peroxy radical **3** with the 1'-nucleoside peroxy radical **13** which was studied recently by M. M. Greenberg et al.¹⁶ (Scheme 4). In contrast to the reversible reaction of 4'-DNA radical **2** with O_2 , the 1'-peroxy radical **13** decomposes into cation **14** and $O_2^{\bullet-}$, if it is not trapped by a H-donor. This remarkable difference between the peroxy radicals evolves from the large stabilization of the positive charge at C-1' by the heterocyclic base.¹⁷

The consequence of our study is that the fast O_2 -induced cleavage of single-stranded 4'-DNA radicals needs a sufficiently high concentration of H-donors in order to trap the intermediate peroxy radical. Studies on biologically more relevant double-stranded 4'-DNA radicals are in progress.¹⁸

Acknowledgment. This work was supported by the Swiss National Science Foundation.

JA980036F

(15) von Sonntag, C.; Hagen, U.; Schön-Bopp, A.; Schulte-Frohlinde, D. *Adv. Radiat. Biol.* **1981**, *9*, 109.

(16) Tallman, K. A.; Tronche, C.; Yoo, D. J.; Greenberg, M. M. *J. Am. Chem. Soc.* **1998**, *120*, 4903.

(17) For a comparison with other peroxy radicals, see: von Sonntag, C.; Schuchmann, H.-P. In *Peroxy Radicals*; Alfassi, Z., Ed.; J. Wiley: New York, 1997; p 173.

(18) First experiments indicate that double-stranded 4'-DNA peroxy radicals release O_2 slower than single-stranded 4'-DNA peroxy radicals.